

129 Oakpark Drive, Unit A, Mooresville, NC 28115
 (704) 937-2673
 BERLS.COM
 BERL'S COMMERCIAL SUPPLY

G02JAS13XX Series Bariatric

Bariatric 24" antimicrobial vinyl coated grab bar. No maintenance 3mm thick antimicrobial vinyl coating. Concealed stainless steel 11-hole flange plate.

Mounting hardware supplied for wood stud installation.

Product Data

Overall Dimensions (Inch.)	27-3/16 x 2-7/8 x 3-1/8
Net Weight (lbs.)	3.64

Installation Hardware Details

Stainless steel screw	TSP 5x60 Inox
-----------------------	---------------

Packaging Details

Package	LDPE bag in cardboard box
Package dimensions (Inch.)	27-5/8 x 3-1/2 x 3-11/16
Weight with Packaging (lbs.)	4.3

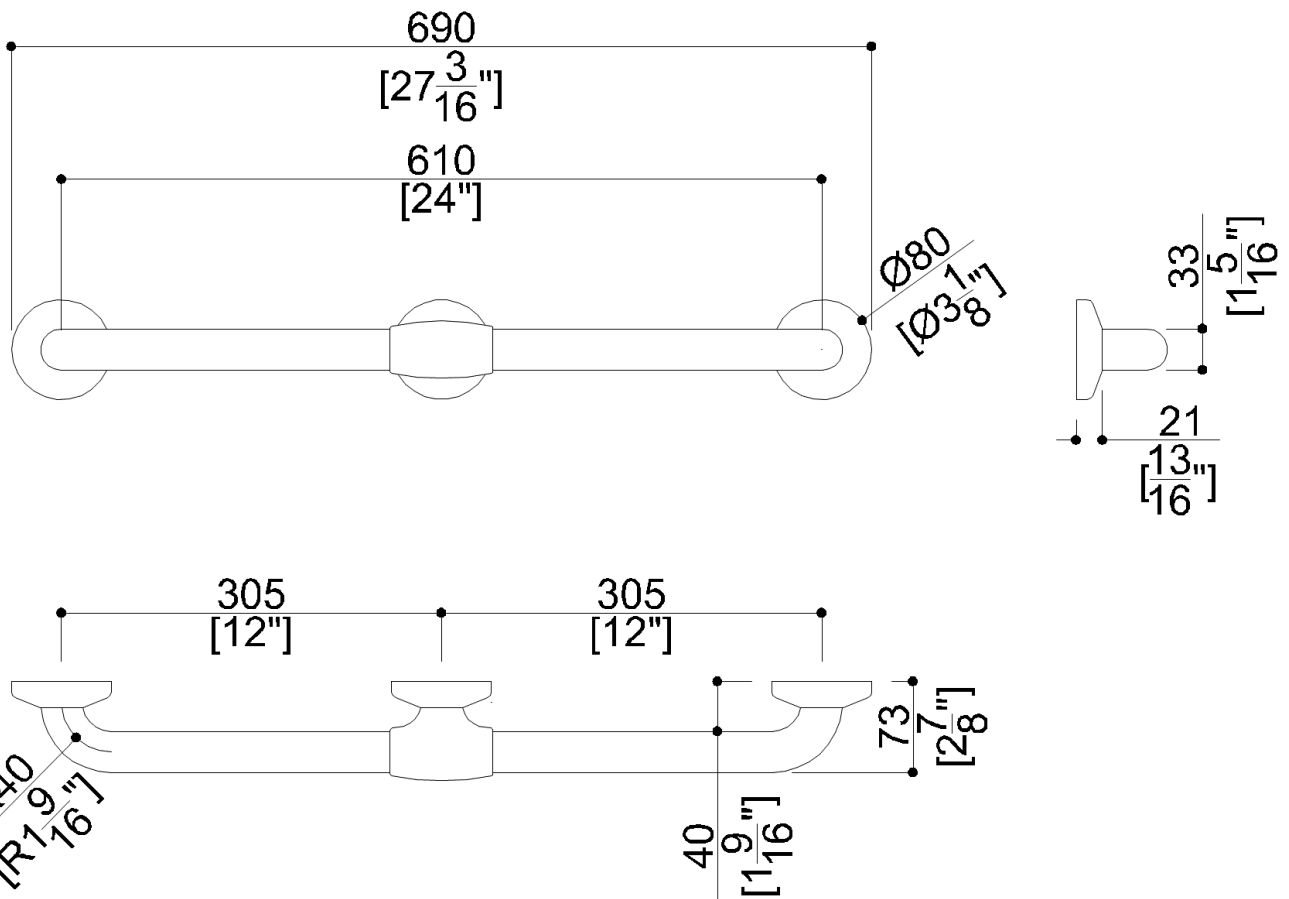

G02JAS13XX Series Bariatric

Y88JKS12

AISI 304 stainless steel fixing plate

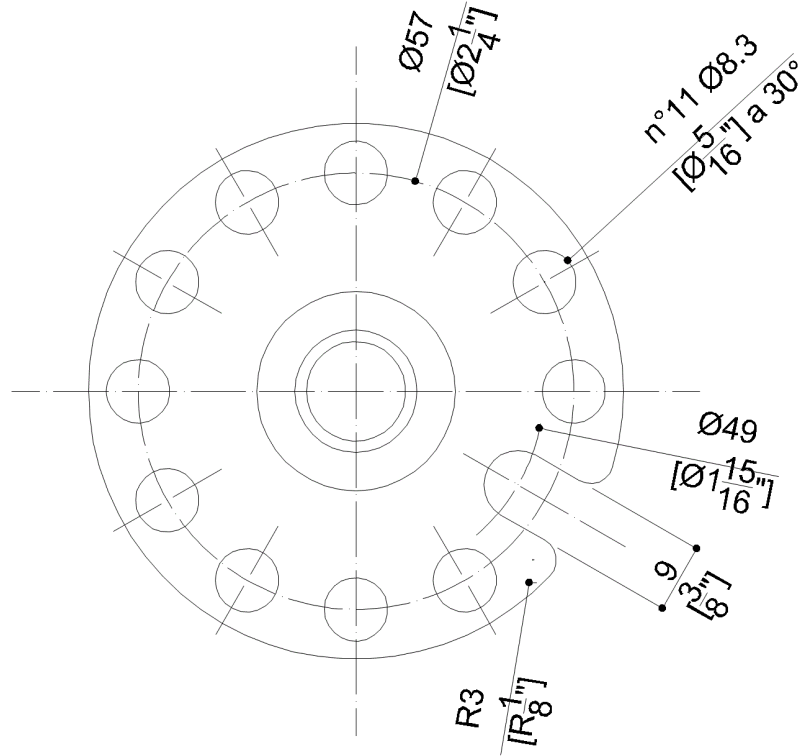

Available Finishes (xx)

W1
 White

Load Capacity

Vertical 1102 lbs.

Warning

Before installation and use, read the installation and use instructions in their entirety. If questions arise please contact Ponte Giulio company.

Cleaning

Product can be cleaned with a cloth and warm soapy water. Non abrasive, solvent free cleaners can also be used.

Warranty

Please visit www.pontegiulio.com for complete warranty details.

Materials and finishes

Steel	Rough
Stainless Steel	Rough
Polyamide	Polished
Vinyl	Polished