

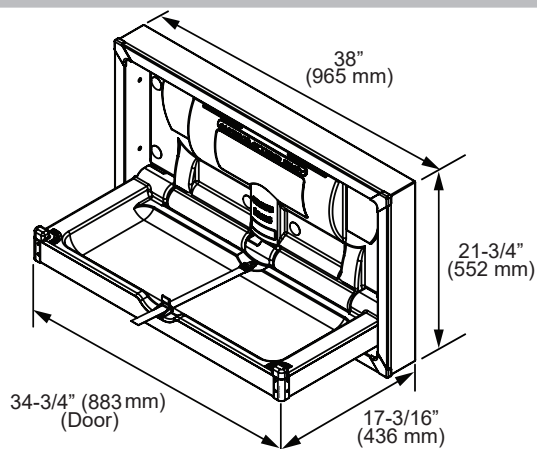

BABY CHANGERS MADE BY BABY EXPERTS.™

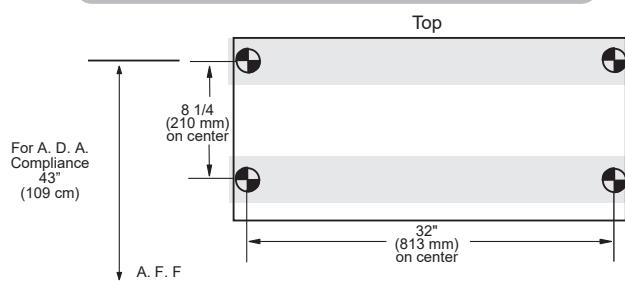

Recommended Blocking Surface Mount



Installation Information

- Unit projects 4" (100mm) when surface mounted.
- Open unit projects from wall 17-3/16" (436 mm) when surface mounted.

Submittal Sheet

Model 100SSC-SM Clad Stainless Steel Diaper Changing Station

- Polyethylene body with stainless steel exterior
- Easy to clean, high density polyethylene which is naturally bacteria resistant, beneath 304 brushed stainless steel encasement.
- Standard with molded-in dual liner dispensers.
- Each liner dispenser holds approximately 50 of the 036-LCR or 036-NWL liners.
- Smooth nylon belt with Thermoplastic Polyurethane coating. Easy to sanitize and adjustable with one hand.
- Convenient bag hooks clearly labeled on both sides
- Easy to read ANSI compliant labels (ANSI Z535.3 and ANSI Z535.4), utilizing universal safety symbols
- Compact, slim profile meets A.D.A. when properly installed. Only protrudes 4 inches or 102 mm from wall.
- Includes universal changing station door sign
- Pneumatic gas shock mechanism to ensure smooth, safe open and close motions.
- Includes easy to install, step-by-step instructions plus all mounting hardware
- ASTM G21 Anti-Fungal: No measurable fungal growth
- Meets or exceeds ASTM F2285 Safety Specifications for Commercial Changing Stations.
- Standard pack: 1 unit
- Limited Warranty: This product is warranted against manufacturing defects for a period of 5 years.

Short Specifications

Polyethylene Diaper Changing Stations with Stainless Steel Exterior:

1. Acceptable Products: Foundations Worldwide Inc. Model 100SSC-R (Clad Horizontal Recessed Mount) & 100SSC-SM (Clad Horizontal Surface Mount)
2. Characteristics:
 - a. Entire body 16 gauge, 304 brushed stainless steel, seamless welds
 - b. Provide Foundations Worldwide Inc. SS flange in order to surface mount unit.
3. Equipped with a pneumatic cylinder
4. Smooth nylon belt with Thermoplastic Polyurethane coating. Easy to sanitize and adjustable with one hand.
5. Meets ASTM F2285 requirements for weight bearing changing stations
6. **A.D.A. Compliance:**

306.3	Knee Clearance
307.2	Maximum Protruding Objects
308.2	Forward Reach
308.3	Side Reach
309.4	Operation
902.3	Work Surface

Compliant when properly installed.
7. ANSI compliant safety labels
8. CPSIA compliant to applicable sections

