

# AIRFORCE™ HAND DRYER



## SPECIFIER'S APPROVAL

Job _____	Date _____
Model Number _____	Quantity _____
Variations _____	Recessing Kit _____
Customer/Wholesaler _____	
Contractor _____	
Architect/ Engineer _____	

Electronic specifications available online: [www.worlddryer.com/specs](http://www.worlddryer.com/specs)

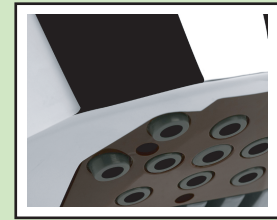

*Fast*

Airforce™ utilizes an innovative warm air Multi-jet hand drying technology.

- High speed - from wet to dry in 12 seconds
- Automatic infrared activation ensures optimum hygiene levels
- Lowest noise level among other high speed hand dryers



*Green*

Airforce™ is the environmentally friendly hand dryer.

- Low energy consumption at 1100 watts
- GreenSpec Listed - considered to be in the top of the class and environmentally preferable
- Can help earn LEED credits based on EA Credit 1 for optimized energy performance



*Clean*

Airforce™ features SteriTouch® anti-microbial technology.

- Drastically reduces the spread of harmful bacteria, mold, and fungi
- Sleek design prevents dirt from collecting and is easy to clean



## WORLD DRYER

5700 McDermott Drive, Berkeley, IL 60163  
800-323-0701 | Fax 708-449-6958  
[www.worlddryer.com](http://www.worlddryer.com)



MODEL NUMBERS

COVER COLOR	MOUNTING OPTIONS	120 volt Models	*208/230 volt Models	220 volt / 50 Hz Export
White	Surface	J-974	*J4-974	J48-974
Black	Surface	J-162	*J4-162	J48-162
Chrome	Surface	J-970	*J4-970	J48-970
ELECTRICAL	Volts	120	208/230	230
	Amps	9.6	4.8	4.8
	Watts	1100	1100	1100
	Hertz	60	60	50

Sound level of 83 dB

\* Available soon!

RECESSING KIT	KJR-973	KJR-973	KJR-973
Stainless Steel, ADA Compliant ♿			

MEASUREMENTS

Surface units	Unit Measurements	10.7" H x 8.9" W x 6.5" D 272 mm x 226 mm x 165 mm
	Weight	7 lbs / 3.18 kgs
	Shipping Dimensions	11.7" H x 10.8" W x 7.2" D 297 mm x 274 mm x 183 mm
Recessing Kit (separate from dryer)	Unit Measurements	13.3" H x 24.6" W x 3" D 338 mm x 625 mm x 76 mm
	Weight	8 lbs / 3.6 kgs
	Shipping Dimensions	5" H x 13.8" W x 24.9" D 338 mm x 351 mm x 76 mm

Dryer protrudes 3.5" from the wall with the use of a recessing kit.

Patent Pending.

# Mounting Charts

SURFACE MOUNTED

RECESS MOUNTED

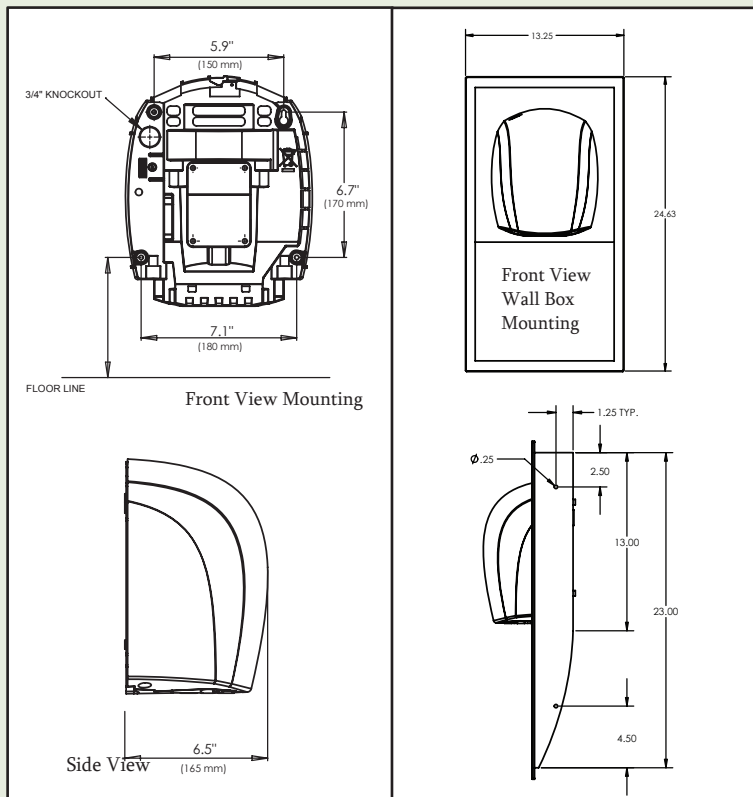

Drawings not to scale

## Specifications

Airforce™ Model J, J4, and J48 hand dryers shall be manufactured by or for World Dryer® Corporation. Dryer assembly to be housed in a die cast Aluminum housing finished in chrome plating or housing finished in epoxy paint that is incorporated with SteriTouch® antimicrobial additive. Motor shall be universal brush type operating at 34000 RPM and shall be thermally protected. It shall deliver 53 cubic feet per minute of air volume (10,500 LFM). Dryer shall be activated by an automatic active infrared sensor controlled by a circuit board with 1 second run-on time and 30 second vandal shut-off. Control board to have conformal coating. Dryer shall provide a 40°F temperature rise, and PC/ABS internal housing components to be V0 or V5 flame retardant. Hand dryers shall be listed under re-examination service of Underwriters Laboratories, Inc. CE e U US

INSTALLATION

Airforce™ hand dryers require a dedicated 15 AMP circuit, and must be properly grounded. GFI circuit protection is recommended. One side of dryer should be mounted to a stud.

5 Year Limited Warranty

PLANNING GUIDE

- Hand Dryer Quantity Estimate
- Average Traffic: 1 dryer per 2 washbasins
- Heavy Traffic: 1 dryer per washbasin
- 54" Bradley sink: 4 dryers per sink

DRYER PLACEMENT

Hand dryers should be placed at least 2 feet apart, near but not over the washbasin. In congested areas dryers should be placed to create a traffic flow from wash basin to dryer to exit. Automatic dryers should be placed more than 18" above or away from projections, which may interfere with the operation of the automatic sensor.



Airforce™ utilizes SteriTouch® patented anti-bacterial technology. SteriTouch® protects from the build-up of germs, mold and bacteria and makes the dryer easy to clean.

SteriTouch® is an antimicrobial additive designed to reduce the growth of harmful organisms such as bacteria, mold and fungi, while remaining entirely safe for even the most sensitive applications.

SteriTouch® is effective against many organisms, including bacteria such as methicillin resistant staphylococcus aureus (MRSA), escherichia coli, pseudomonas aeruginosa, salmonella enteritidis and listeria monocytogenes, and molds such as aspergillus niger.

www.steritouch.com