

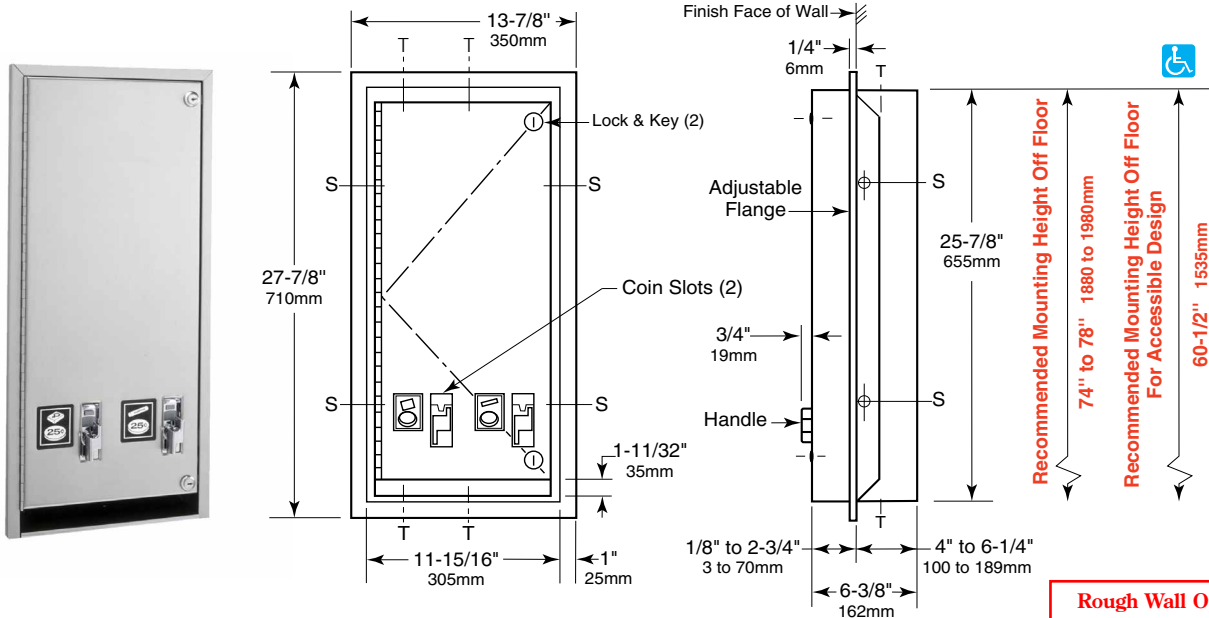

RECESSED SEMI-RECESSED NAPKIN/TAMPON VENDOR

352 25



Rough Wall Opening
 12-1/2" (320mm) wide
 26-3/8" (670mm) high
 2-3/4" to 6-3/8"
 (70 to 162mm) minimum
 recessed depth

MATERIALS:

Cabinet — 18-8, type-304, 22-gauge (0.8mm) stainless steel. All-welded construction.

Flange — 18-8, type-304, 22-gauge (0.8mm) stainless steel with satin finish. One-piece, seamless construction with 1/4" (6mm) return for rigidity. Adjustable escutcheon-type flange permits semi- or fully-recessed installation.

Door — 18-8, type-304, 18-gauge (1.2mm) stainless steel with satin finish. Secured to cabinet with a full-length stainless steel piano-hinge. Equipped with two tumbler locks keyed like other Gamco restroom accessories. Door has no brand-name advertising for products dispensed. International graphic symbols identify products dispensed and coin denomination.

Coin Mechanisms (2) — Single-coin mechanisms for 25¢ operation. Each coin box is equipped with a tumbler lock and opens with different key than furnished for door. Coin mechanisms do not require lubrication. All moving parts are replaceable without removing cabinet from wall.

OPERATION:

After coin is inserted in dispensing mechanism of patron's choice, turning appropriate handle dispenses boxed sanitary napkin or tampon tube. Coin slot of each dispensing mechanism is identified by an international graphic symbol. Capacity: 30 sanitary napkins and 27 tampons. Coin slots are blocked when supply is depleted. Vendor dispenses sanitary napkin packages measuring 3" x 1" x 4-1/4" (75 x 25 x 110mm) and tampon packages measuring 5-1/8" long x 11/16" diameter (130 x 17mm).

INSTALLATION:

Provide framed rough wall opening 12-1/2" wide x 26-3/8" high (320 x 670mm). Minimum recessed depth required to finish face of wall for fully recessing the unit is 6-3/8" (162mm). Allow clearance for construction features that may protrude into opening from opposite wall. Coordinate with mechanical engineer to avoid pipes, vents, and conduits. If unit projects above top of wainscot, provide aluminum channel or other filler to eliminate gap between flange and finish face of wall. Mount flange in rough wall depth with four sheet-metal screws, furnished by manufacturer, at points indicated by an S. Insert cabinet into flange to wall depth available, then secure unit with four sheet-metal screws, furnished by manufacturer, at points indicated by a T.

SPECIFICATION:

Recessed napkin/tampon vendor shall combine two dispensing mechanisms in one cabinet to provide sanitary napkins or tampons at user's option. Unit shall be type-304 stainless steel with all-welded construction; exposed surfaces shall have satin finish. Door shall be 18 gauge (1.2mm), secured to cabinet with a full-length stainless steel piano-hinge, and equipped with two tumbler locks keyed like other Gamco restroom accessories. Each coin box shall be equipped with a tumbler lock that is keyed differently than door locks. Vendor shall be equipped with 25¢ coin mechanisms and shall carry no brand-name advertising.

Recessed/Semi-Recessed Napkin-Tampon Vendor shall be model Model 352 25 of Gamco Commercial Restroom Accessories, One Gamco Place, Durant, OK, 74701-1910