

PRODUCT SPECIFICATIONS

Elkay Yard Hydrant with Locking Hose Bib, Non-Filtered Non-Refrigerated. Features shall include E-coat, Heavy Duty Vandal Resistant. Product shall be Floor Mount/Freestanding, serving 0 station(s).

Special Features:	E-coat, Heavy Duty Vandal Resistant
Finish:	Beige (BGE), Black (BK), Blue (BLU), Brown (BRN), Evergreen (EVG), Gray (GRY), Orange (ORN), Powder Coat (12 Color Options), Purple (PUR), Red (RED), Terracotta (TER), White (WHT), Yellow (YLW)
Power:	No Electrical Required
Bubbler Style:	No Bubbler
Mounting Type:	Floor Mount/Freestanding
Chilling Capacity:	Non-refrigerated
Approx. Shipping Weight:	108 lbs.
No. of Stations Served:	0

- Unique E-Coat immersion process coats the inside and outside of the fountain for ultimate corrosion protection.



Ships in one box.

AMERICAN PRIDE. A LIFETIME TRADITION.
Like your family, the Elkay family has values and traditions that endure. For almost a century, Elkay has been a family-owned and operated company, providing thousands of jobs that support our families and communities.



PART: _____ QTY: _____

PROJECT: _____

CONTACT: _____

DATE: _____

NOTES: _____

APPROVAL: _____

In keeping with our policy of continuing product improvement, Elkay reserves the right to change product specifications without notice. Please visit elkay.com for the most current version of Elkay product specification sheets. This specification describes an Elkay product with design, quality, and functional benefits to the user. When making a comparison of other producers' offerings, be certain these features are not overlooked.

Optional Accessories

[97890C](#)

Accessory - Direct Bury Adaptor
[Spec Sheet \(PDF\)](#)



OPERATING PRESSURES:

Supply water 20 – 105 psi maximum

MOUNTING INSTRUCTIONS and PLUMBING CONNECTIONS

Provide solid, well-drained surface to mount hydrant (concrete pad recommended.) (6) 3/8" minimum fasteners (not included) should be attached securely to mounting surface in order to secure fountain. (Refer to rough-in diagram.)

Locate and install plumbing through ground as required.

NOTE: Hydrant is not furnished with service valve.

Position hydrant over plumbing and secure base to fasteners. Remove access panel and connect supply and water lines. Turn on water supply and check for leaks. Reassemble access panel to pedestal. Refer to owners' manual for detailed instructions.

Hydrant is rated for inlet water pressure of 20-105 psi. A pressure reducing regulator should be used if the inlet water supply exceeds 105 psi.

NOTE: Not designed for sub-freezing applications.

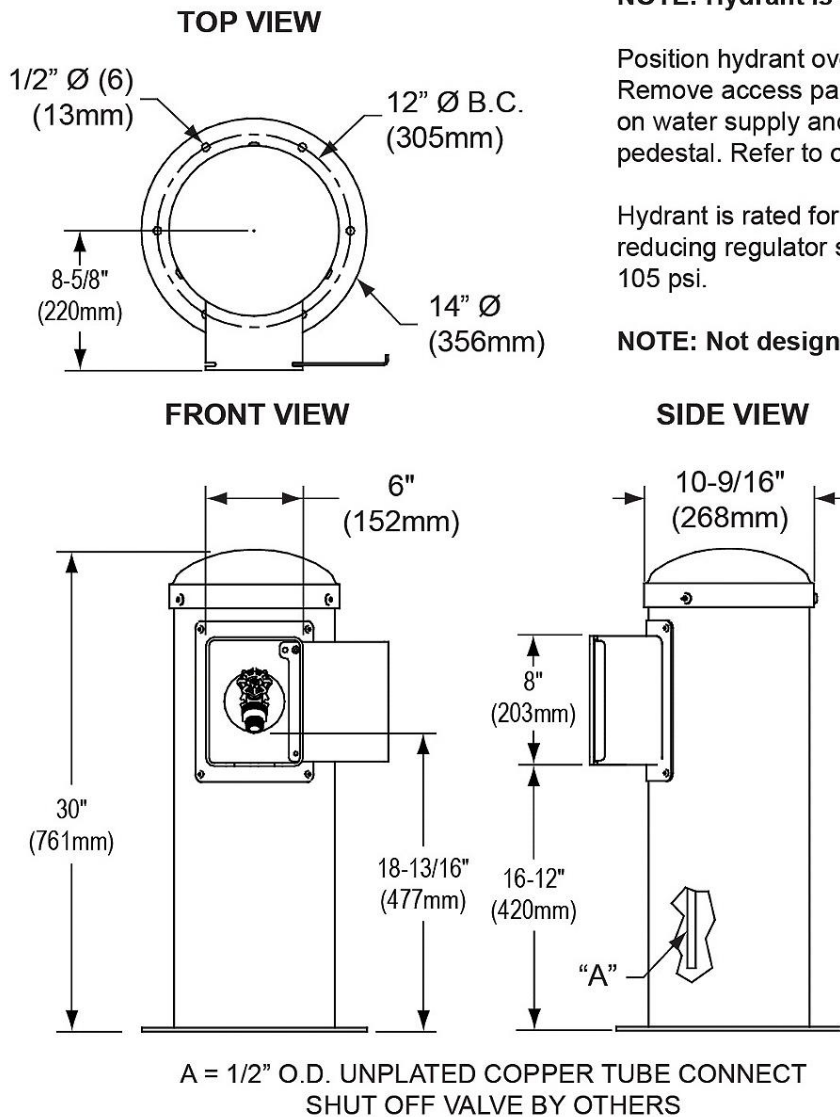

In keeping with our policy of continuing product improvement, Elkay reserves the right to change product specifications without notice. Please visit elkay.com for the most current version of Elkay product specification sheets. This specification describes an Elkay product with design, quality, and functional benefits to the user. When making a comparison of other producers' offerings, be certain these features are not overlooked.