

# Owners Manual

## Outdoor Bottle Filler Foot Pedal Accessory For Use On Following Series Fountains With Floor Mount Base

### Elkay Series:

LK4400BF  
LK4420BF1U  
LK4420BF1UDB

### Halsey Taylor:

4400BF  
4420BF1U  
4420BF1UDB

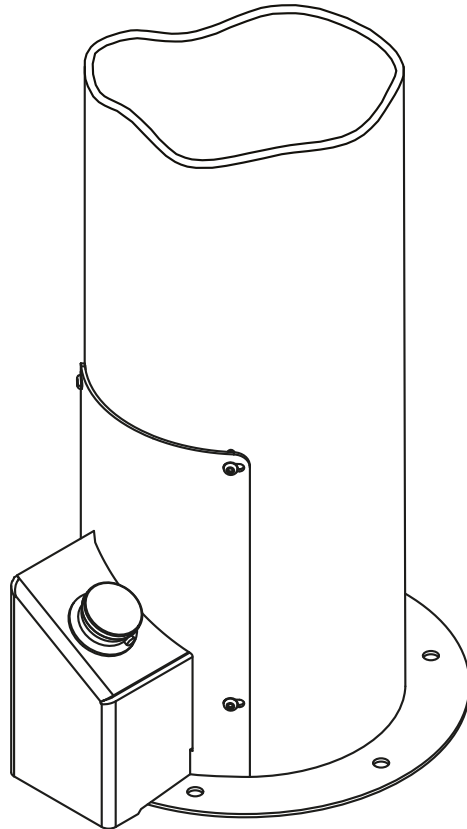

### Installer

To assure you install this accessory easily and correctly, PLEASE READ THESE SIMPLE INSTRUCTIONS BEFORE STARTING THE INSTALLATION. CHECK YOUR INSTALLATION FOR COMPLIANCE WITH PLUMBING, ELECTRICAL AND OTHER APPLICABLE CODES.

## INSTALLATION INSTRUCTIONS

- 1) Shut off the water to the fountain. Press the push button(s) to relieve the remaining water pressure from the unit.
- 2) Using the supplied T-27 torx head bit and a bit holder, remove all 8 screws securing the upper and lower access panels located on the side of the fountain. See Fig.7 and 5.

**Note:** Foot pedal will replace the lower access panel.

- 3) Through the lower access panel opening, locate the 3/8" water inlet copper tube at the bottom of the fountain and cut it, leaving enough on both sides to insert the supplied 3/8" Tee.
- 4) Take one of the 3/8" Tees and insert the copper tube, in-line strainer and 6" of the 1/4" poly tubing as shown. After assembled, attach the 3/8" Tee to the 3/8" water inlet copper tubing where it was cut in Step 3. See Fig.1 and 6.
- 5) Take the 1/4" poly tubing from the water line assembly and insert into the inlet side of the regulator on the foot pedal. See Fig.2 and 6.
- 6) Take the remaining supplied 3/8" Tee and connect one end of the 3/8" poly tubing into it as shown. See Fig.3 and 8.
- 7) Slide the black insulation onto the 3/8" poly tubing and then cut off remaining insulation at the end of the tubing.
- 8) Connect the 3/8" poly tubing to the 3/8" x 1/4" fitting. Cut another 1/4" poly tubing to 6 inches and then insert into the open end of the fitting. See Fig.4 and 6.
- 9) Looking into the fountain from the upper access panel, locate the 3/8" water line leading from the bottle filler push button to the bottle filler; cut it, leaving the enough on both sides to insert the supplied 3/8" Tee. See Fig.3, 7 and 8.
- 10) Place the 3/8" poly tubing inside the fountain body and arrange it to be accessible from the lower access opening. Take the 1/4" poly tubing and insert it into the regulator. See Fig.6.

### Panel(s) Installation

- 11) Turn on the main water supply. Check for leaks and ensure proper function of foot pedal and existing push button. If there are leaks, turn off the water supply and correct the water leaks as required.
- 12) After ensuring that all connections are leak free, leave the main water supply on and install the upper access panel with its 4 screws. Use the T-27 torx head bit and a bit holder to tighten. See Fig.7.
- 13) Secure the foot pedal body to the fountain body with the 4 screws provided. Use the T-27 torx head bit holder to tighten. See Fig.5.
- 14) Installation of foot pedal is complete.

## TOOLS REQUIRED (NOT PROVIDED)

- 1) Gloves
- 2) Safety Glasses
- 3) Tubing Cutter
- 4) Utility knife
- 5) Bit holder

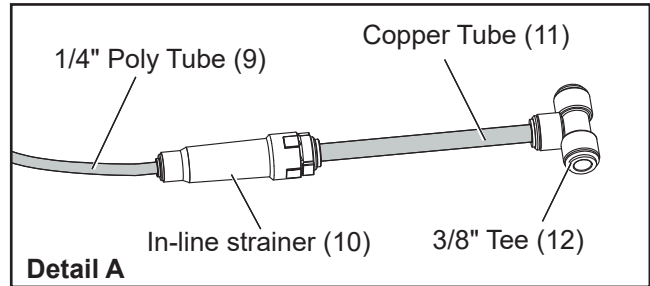

Fig.1

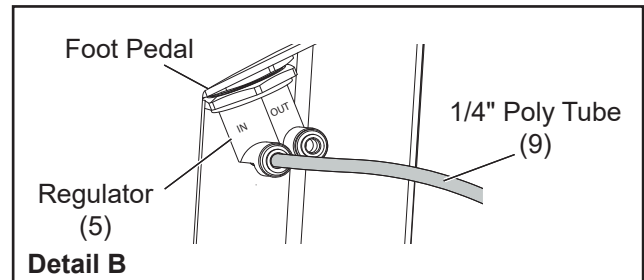

Fig.2

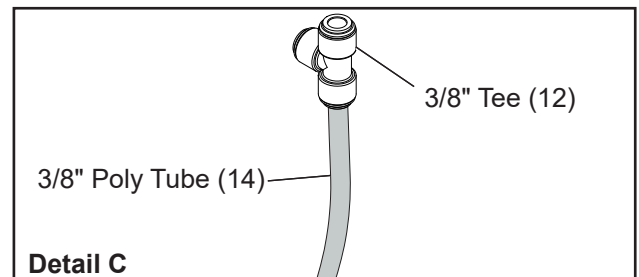

Fig.3

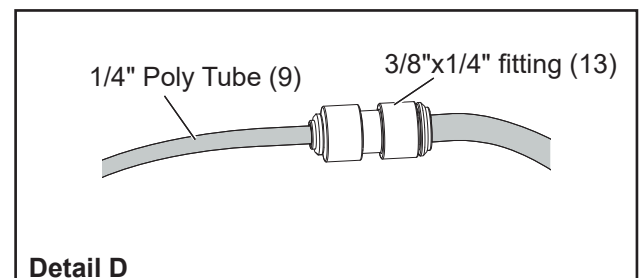
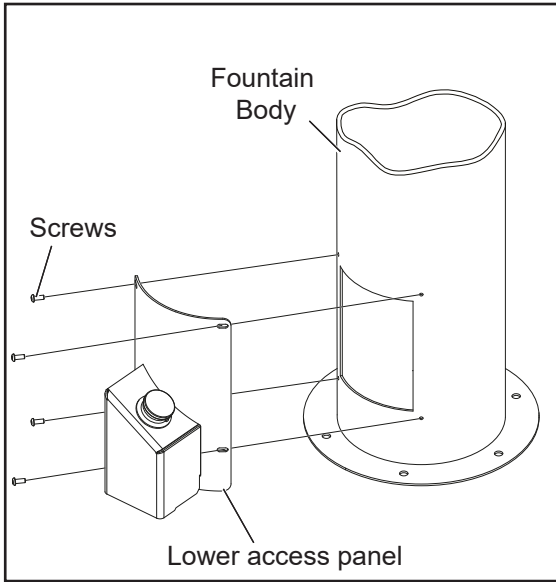
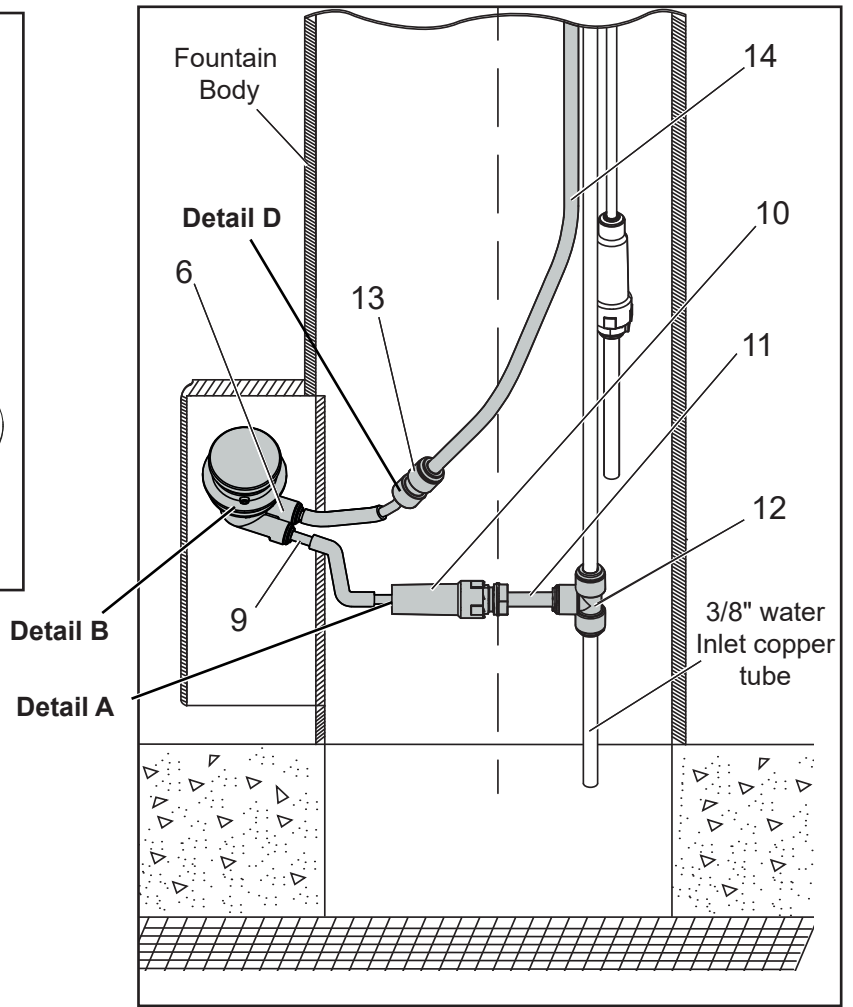

Fig.4

**Note:** See Fig.6 and Fig.8 for Details A, B, C and D



**Lower Fountain  
Fig.5**



**Lower Fountain Internal View  
Fig.6**

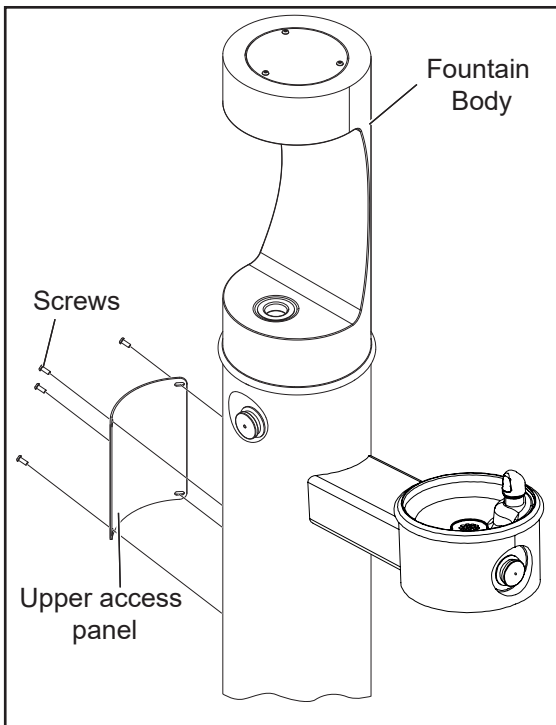

**Upper Fountain  
Fig.7**

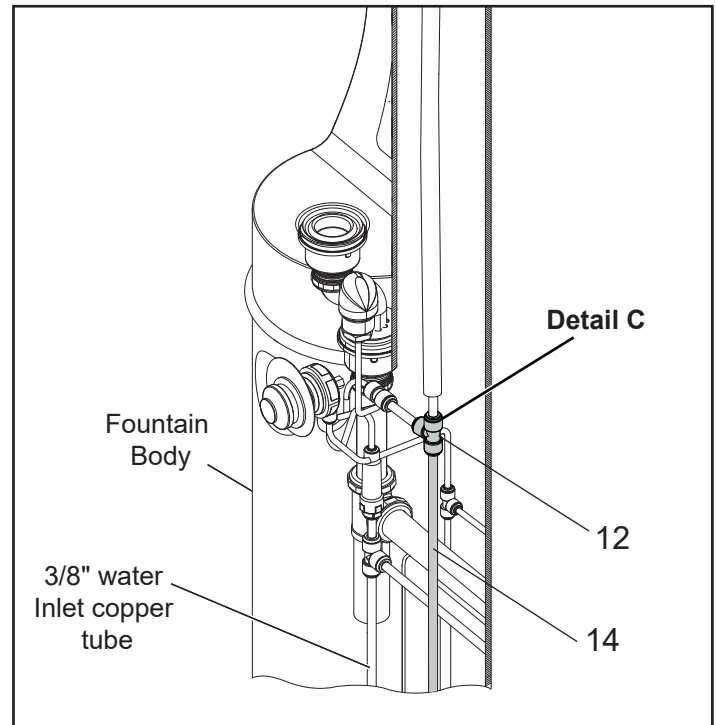

**Upper Fountain Bottle Filler Internal View  
Fig.8**

**Parts List**

ITEM NO.	DESCRIPTION
1	Assy, 4481 FP Foot Activation
2	Washer-Spacer 2.00 O.D.
3	Nut-Hex 1-5/16"
4	1-1/8"-24 Retaining Nut
5	Regulator - High Flow Wras
6	Holder - Regulator
7	Sleeve - Push Button Guide
8	Button - Push w/o Hole
9	Tube-Poly 1/4"X.040 Wall
10	Strainer - In Line Wras
11	Tube - Cu 3/8" X 4.75 (1-P117)
12	Fitting Tee - 3/8"
13	Fitting - Union-3/8" X 1/4 Union
14	Tube-Poly 3/8"X.062 Wall
15	Screw-Cap #6-32
16	Insulator-Tube 3/8"-3/16 Bulk

**Replacement Parts List**

ITEM NO.	PART NO.	DESCRIPTION
17	1000006235	4481FP - Outdoor Fountain Foot Activation - Push Button Service Kit
18	1000006234	4481FP - Outdoor Fountain Foot Activation - Regulator Service KIT

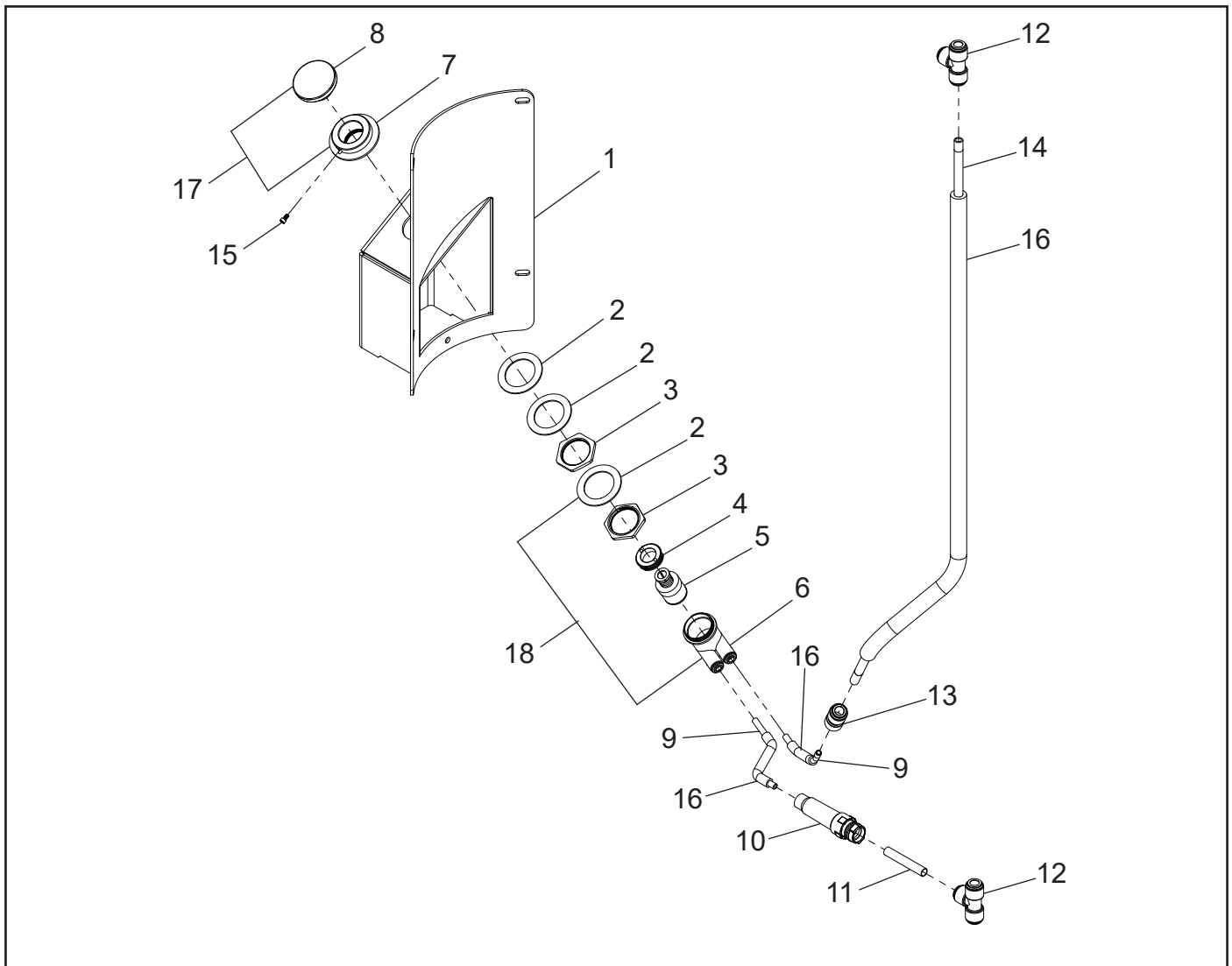

**Foot Pedal Exploded View**

PRINTED IN U.S.A.  
 Halsey Taylor – halseytaylor.com  
 Elkay – elkay.com

FOR PARTS CONTACT YOUR LOCAL DISTRIBUTOR OR CALL TECHNICAL SERVICES AT 1.800.834.4816  
 1333 BUTTERFIELD ROAD SUITE, 200 DOWNERS GROVE, IL60515