

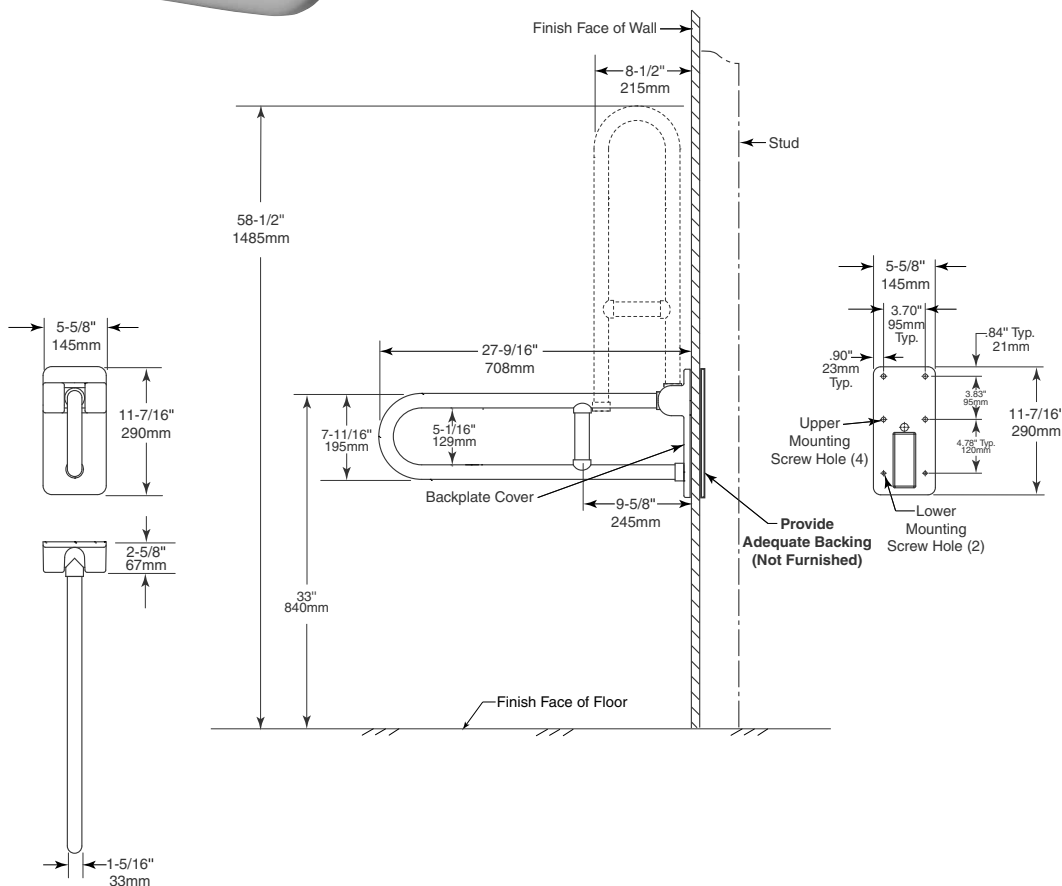

Technical Data

VINYL-COATED SWING UP GRAB BAR

B-49916



MATERIALS:

Grab Bar — Seamless zinc-plated 3/4" steel pipe with 1/8 inch (3mm) thick W1 white vinyl antibacterial, biocompatible, and warm-to-the touch coating. 1-5/16" (33mm) outside diameter.

Backplate — 3/16" (4mm) thick Type 304 stainless steel.

OPERATION:

Swing-up grab bar is manually raised for approach or departure and lowered to horizontal position for support; grab bar is raised to upright position against wall and remains in vertical position until lowered to horizontal position.

continued . . .

STRENGTH:

Swing-up grab bar withstands loads 330 pounds (150kg) if properly installed, complying with accessible design guidelines (including ADAAG in the U.S.A.) for structural strength.

Safety Warning: Grab bars are no stronger than the anchors and walls to which they are attached and, therefore, must be firmly secured in order to support the loads for which they are intended. To avoid potential injury, the building owner or maintenance personnel should remove the grab bar from service if the grab bar is not adequately secured to wall or if there is any observed damage to the welds.

INSTALLATION:

Remove black plastic Wall Plate from rear of Grab Bar Backplate. Provide Concealed Anchor Device or backing as specified or required in accordance with local building codes before wall is finished. Once desired mounting location is determined, black plastic Wall Plate may be used as a template to mark locations of mounting screws on finished wall, as necessary.

Mount Wall Plate on finished wall. Lower two mounting screw locations to be drilled to accept two 2-1/2" (65mm) long #10 Phillips sheet metal screws (furnished). Upper four mounting bolt locations to be drilled to accept four 3" (75mm) long 5/16" hex-head lag bolts (furnished). Secure Wall Plate to wall at lower two mounting screw locations with Phillips sheet metal screws.

Mount Folding Grab Bar to Wall Plate and concealed anchor device or backing (not furnished). Pull white plastic Backplate Cover away from metal Grab Bar Backplate. Securely mount Grab Bar to Wall Plate/wall at upper four mounting bolt locations of Wall Plate with hex-head Lag Bolts, through Backplate and Wall Plate into wall.

Fold Grab Bar up into the vertical position. Locking nuts at the sides of the pivot assembly are to be adjusted to ensure that Grab Bar remains in vertical position after it is rotated up. Snap Backplate Cover into place over Grab Bar Backplate and Wall Plate.

Optional anchor devices and/or fasteners (not provided) may be used, subject to type of wall on which the grab bar will be mounted, but would also be subject to local building codes for safe grab bar mounting.

CLEANING AND MAINTENANCE:

DO NOT USE abrasive liquid detergents. Chlorine bleach does not improve the aseptic aspect of the equipment and could lead to opacity and deterioration of the material.

DO NOT USE hot air with a temperature over 80°C (175°F) for drying the device.

SPECIFICATION:

Vinyl-Coated Swing-Up Grab Bar with reinforced joint shall be corrosion resistant, zinc coated steel pipe with vinyl antibacterial, biocompatible and warm-to-the touch coating. Grab bar shall have 1/8" (3mm) wall thickness, 1/8" (3mm) extruded plastic finish coating thickness and 1-5/16" (33mm) outside diameter. Back plate shall be 3/16" (4mm) thick AISI 304 stainless steel, equipped with screw holes for attachment to wall. Swing-up grab bar shall be manually raised for approach or departure and lowered to horizontal position for support; grab bar is raised to upright position against wall and remains in vertical position until lowered to horizontal position.

Vinyl-Coated Swing-Up Grab Bar shall be Model B-49916 of Bobrick Washroom Equipment, Inc., Clifton Park, New York; Jackson, Tennessee; Los Angeles, California; Bobrick Washroom Equipment Company, Scarborough, Ontario; Bobrick Washroom Equipment Pty. Ltd., Australia; and Bobrick Washroom Equipment Limited, United Kingdom.