



AMERICAN SPECIALTIES, INC.
 441 Saw Mill River Road, NY 10701
 (914) 476.9000 • (914) 476.0688
 www.americanspecialties.com

MODEL №: 3100

ISSUED: 01/87

REVISED: 11/09

1-1/4" DIA (Ø32) GRAB BAR SERIES WITH FLANGES FOR CONCEALED MOUNTING

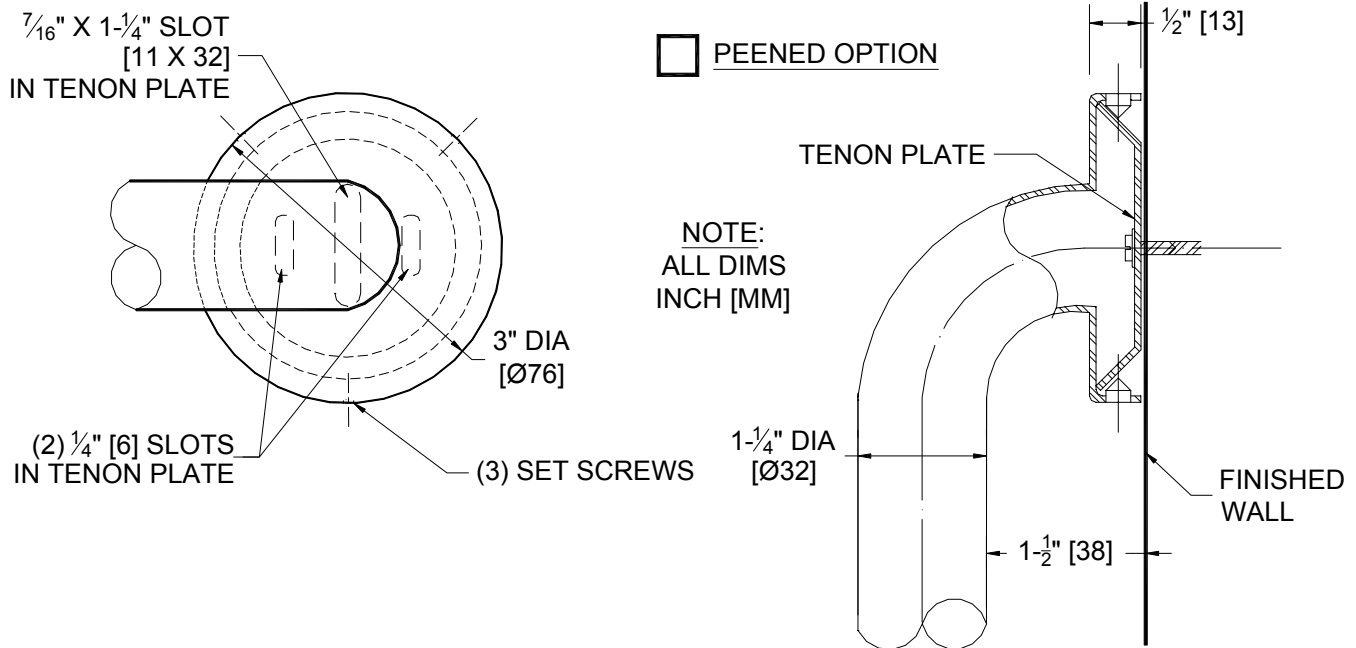

SPECIFICATION

Grab Bar with Flanges for Concealed Mounting shall be type 304 stainless steel alloy 18-8. Tubing shall be 1-1/4" diameter (Ø32) x 18 gauge [0.048"] (1.2). Flange shall be 11 gauge 1/8" (3) thick and shall be Heliarc welded to tubing with a continuous concealed bead. Three (3) tamper resistant 1/4-28 stainless steel hex socket headless setscrews shall be supplied for each flange. Mounting Tenon plates shall be Zinc Chromate plated case hardened steel 13 gauge [0.09"] (2.3) thick. Mounting Tenon plates shall have two (2) 1/4" (6.4) wide x 7/8" (22) long and one (1) 7/16" (11) wide x 1-1/4" (32) long obround mounting slots. All exposed surfaces shall have a satin finish and shall be protected during shipment with a plastic bag. For optional non-slip surface add suffix -P (peened).

1-1/4" Diameter (Ø32) Grab bar with Flanges for Concealed Mounting shall be Series № 3100 of American Specialties, Inc., 441 Saw Mill River Road, Yonkers, New York 10701- 4913

STRENGTH

ASI Grab Bars are designed to meet and exceed ADA requirements as published in CABO/ANSI A117.1-2003 and CFR 28 Part 36, 1 July 1994, section 4.26.3 and FAB-ADA-ABA Regulations of 23 July 2004 Section 609. Mounting to the wall is a critical part of the system to meet this requirement. To withstand the shear, tension or pullout, and torsion loads generated by the maximum loading, the fastener system must be adequately sized.

INSTALLATION

Tenon plates are secured to wall with a 1/4" diameter (Ø6.4) bolt and flat washer (by others) through an elongated slot that provides 1" (25) vertical range and 3/16" (5) horizontal range for fitting adjustment or other fastener system (by others) to suit conditions for each flange. Flanges are then fitted over Tenon plates and secured by tightening the hex socket set screws (provided) to secure. Appropriate anchoring and backing must be provided in accordance with local building codes or as specified on Architects Plans prior to wall finishing. For compliance with ADA Accessibility Guidelines install unit so that the top of the grab bar is 33" (840) minimum above finished floor (AFF) to 36" (915) maximum AFF. Anchors are available from ASI and must be specified separately for each grab bar style scheduled (see 3900 series).