



AMERICAN SPECIALTIES, INC.
 441 Saw Mill River Road, NY 10701
 (914) 476.9000 • (914) 476.0688
 www.americanspecialties.com

MODEL №: 20692

ISSUED: 06/10

REVISED:

ROVAL™ SURFACE MOUNTED SHELF

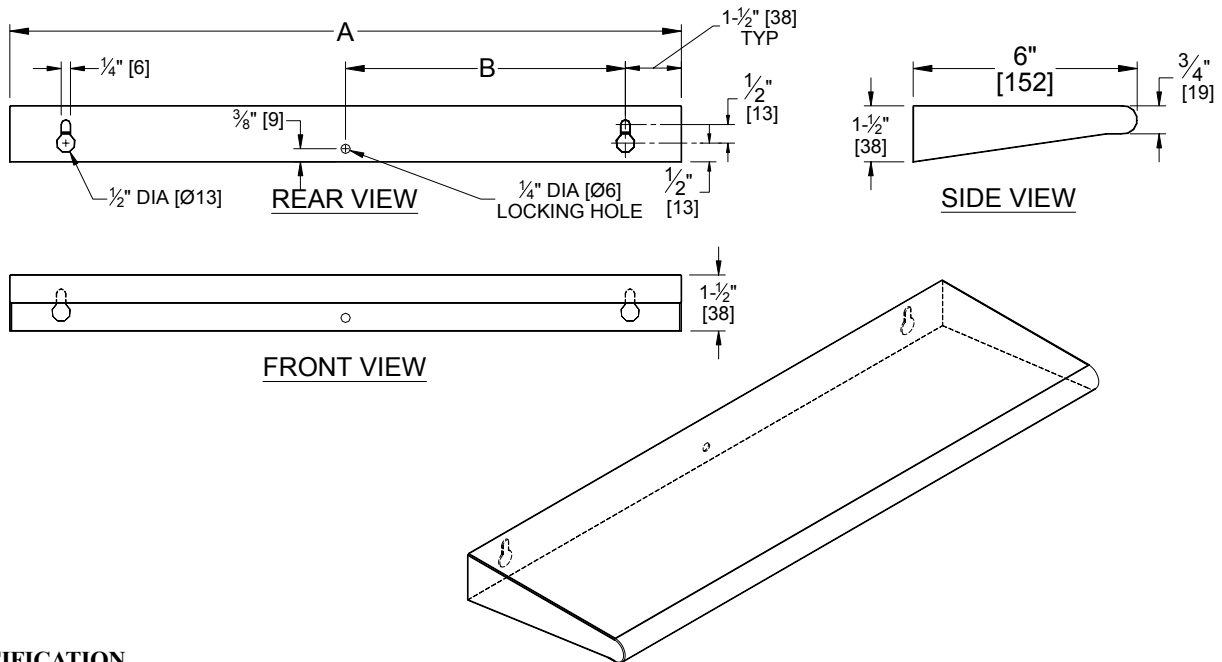

SPECIFICATION

Roval™ Collection Surface Mounted Shelf shall be fabricated of 18 gauge type 304 stainless steel alloy 18-8. Brackets at sides and back shall be integrally formed seamless with shelf and 3/4" (19) curved front edge. Front edge bottom return lip shall be hemmed for safety. All exposed surfaces shall be satin finish and shall be protected during shipment with PVC film easily removable after installation. Shelf shall be sized as per standard schedule or shall be custom fabricated to customer supplied drawing.

Roval™ Collection Surface Mounted Shelf shall be Model № 20692-xxx as manufactured by American Specialties, Inc., 441 Saw Mill River Road, Yonkers, New York 10701-4913

SCHEDULE OF AVAILABILITY

SHELF WIDTH & MODEL SUFFIX ADDER		SHELF MOUNTING HOLE SPACING		
6" (152) depth/length	Specify depth/length	A = Length	B = Spacing	C = Number of Keyholes
-612	-XX12	12" (305)	4-1/2" (114)	2
-616	-XX16	16" (406)	6-1/2" (165)	2
-618	-XX18	18" (457)	7-1/2" (191)	2
-624	-XX24	24" (610)	10-1/2" (267)	2
-630	-XX30	30" (762)	6-3/4" (171)	4
-636	-XX36	36" (914)	8-1/4" (210)	4
-648	-XX48	48" (1219)	11-1/4" (286)	4
-660	-XX60	60" (1524)	14-1/4" (362)	4
-672	-XX72	72" (1829)	11-1/2" (292)	6
-6AA	-DDAA	AA" (A mm)	BB" (B mm)	N

INSTALLATION

Unit is surface mounted on wall or partition using (#C) № 12AB-14 or № 12BP-14 (M6) self-tapping pan head screws or other appropriate fasteners (by others) through (#C) keyholes and one (1) locking hole provided in rear support bracket. Ensure that adequate in wall blocking or other reinforcement is provided (by others) to support shelf and intended loading weight. For compliance with ADA Accessibility Guidelines unit should be installed so that shelf top is between 48" (1219) maximum above finished floor (AFF) and 32" (813) minimum AFF. Typical for general utility is 42" (1067) AFF or 18" (457) above washbasin.

OPERATION

Shelf is stable and stationary after proper and secure mounting to adequate wall reinforcement or stud structure. Shelf is suitable for wet (self-contained) or dry materials storage.

Accessory Specialties

AMERICAN DISPENSER

Desert Ray Products

WATROUS, INC.

THIS MANUFACTURER RESERVES THE RIGHT TO MAKE CHANGES IN DESIGN OR DIMENSIONS WITHOUT FORMAL NOTICE