



AMERICAN SPECIALTIES, INC.

441 Saw Mill River Road, Yonkers, NY 10701 (914) 476-9000

MODEL No: 04684

ISSUED: 1-87

REVISED: 9-04

RECESSED DUAL SANITARY NAPKIN / TAMPON DISPENSER (PAGE 1 OF 2)

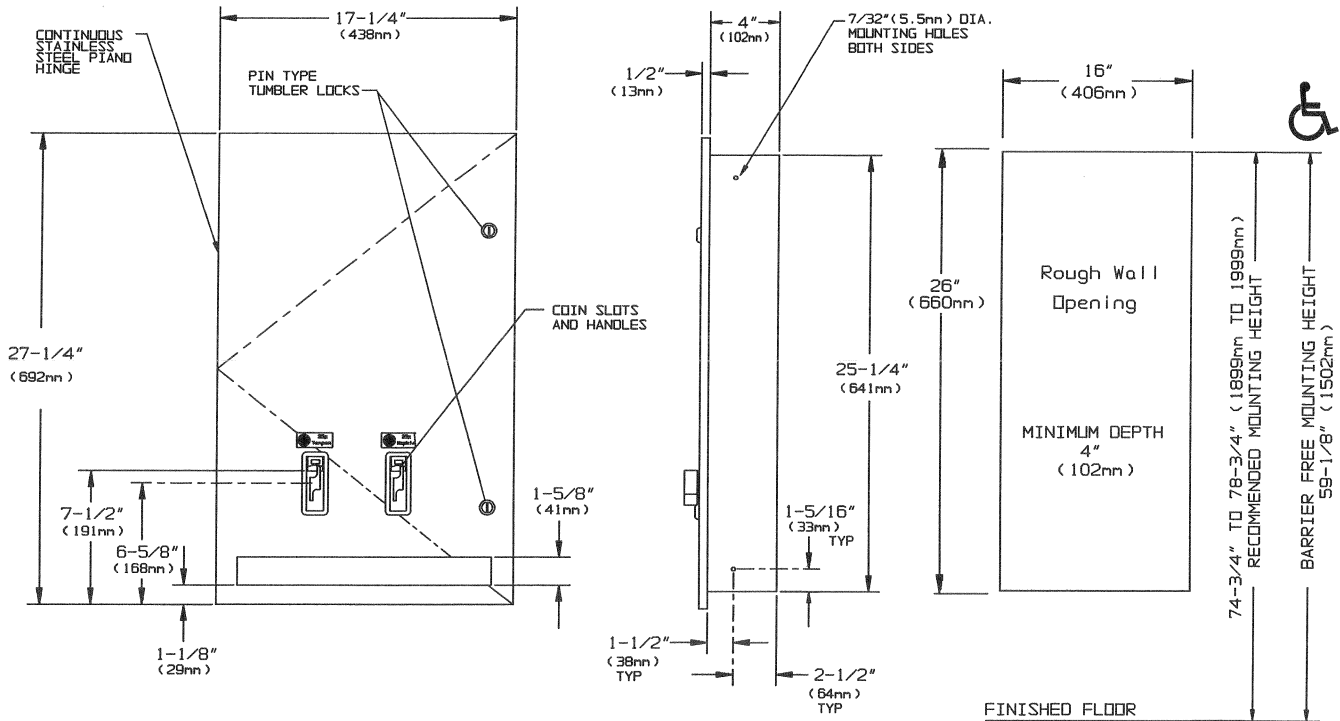

SPECIFICATION

Sanitary Napkin / Tampon vendor shall dispense 15 napkins and 23 tampons of specified sizes and shall have cabinet fabricated of alloy 18-8 stainless steel, type 304, 18 gauge; all exposed surfaces shall have N^o 4 satin finish and be protected during shipment with a PVC film easily removable after installation. Door shall be fabricated of 18 gauge same grade stainless steel and shall be attached to cabinet with a full length 3/16" dia. (5mm) stainless steel multi-staked piano hinge and shall be held closed with two (2) tumbler locks keyed alike to other ASI Washroom Equipment. Internal coin-box shall be keyed differently than door locks. Dispensing mechanisms shall be fastener mounted internally to provide ability to change mechanisms for coinage denomination. Structural assembly of body and door components shall be of welded construction and have no exposed fasteners or welded seams. Weights for each feed track shall be supplied. Factory installed coin operation denomination shall be _____ (please fill in 25¢ or 50¢ or FREE) and add denomination as suffix to model N^o (ie: 04684-25).

Sanitary Napkin / Tampon Vendor shall be Model N^o 04684-xx as manufactured by American Specialties, Inc., 441 Saw Mill River Road, Yonkers, New York 10701-4913

INSTALLATION

Unit is mounted in wall recess using N^o 10 self-tapping screws (by others). Note that coin slot is 6-7/8" (175mm) above bottom edge of rough wall opening.

Rough Wall Opening required is..... 16"W x 26"H x 4"D minimum (406mm x 660mm x 102mm).

Accessory Specialties

AMERICAN DISPENSER

Desert Ray Products

WATROUS, INC.

THIS MANUFACTURER RESERVES THE RIGHT TO MAKE CHANGES IN DESIGN OR DIMENSIONS WITHOUT FORMAL NOTICE



AMERICAN SPECIALTIES, INC.

441 Saw Mill River Road, Yonkers, NY 10701 (914) 476-9000

MODEL No: 04684

ISSUED: 1-87

REVISED: 9-04

RECESSED DUAL SANITARY NAPKIN / TAMPON DISPENSER (PAGE 2 OF 2)

OPERATION

Deposit of specified coin allows operation of dispenser. Napkin and tampon dispensers operate independently. Selected product drops into vending opening after operator actuation. Indicator displays empty condition and blocks coin slot when product is depleted. Unit vend product supply is replenished on cycle determined by maintenance needs by opening door and manually reloading product into dispenser supply tracks. Track weights **MUST BE USED** to provide positive feed.

NAPKINS, SINGLES, CARDBOARD-BOXED, SEMIGLOSS FINISH; CAPACITY: 15, BOX SIZE: 4-1/4" x 3" x 1-1/8" (108mm x 76mm x 29mm)

Stayfree	No. 4
Guards	No's. 247, or 147
Kotex	No's. 704, 707, 07010, 07040, 07045, 07300, 07320
Pure-Nat	No. M-4
Modess	No. 4

TAMPONS, CYLINDER, CARDBOARD, SEMIGLOSS, CRIMPED ENDS; CAPACITY: 23, TUBE SIZE: 3/4" dia. x 5-1/4" (19mm x 134mm)

Tampax	
Modess Tampons	

Accessory Specialties

AMERICAN DISPENSER

Desert Ray Products

WATROUS.INC.

THIS MANUFACTURER RESERVES THE RIGHT TO MAKE CHANGES IN DESIGN OR DIMENSIONS WITHOUT FORMAL NOTICE



AMERICAN SPECIALTIES, INC.

441 Saw Mill River Road, Yonkers, NY 10701 (914) 476-9000

SM-COLLAR

ISSUED: 1-87

REVISED: 3-99

SURFACE MOUNTING COLLAR

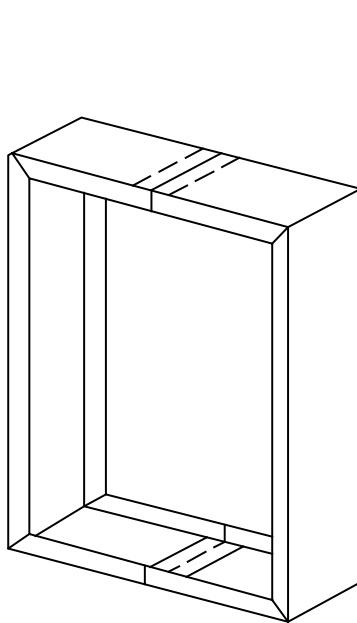

ISOMETRIC OF COLLAR

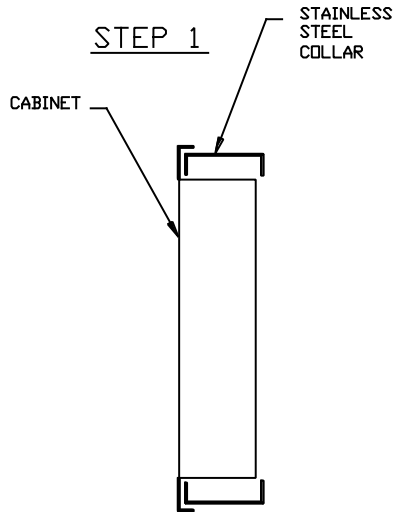

COLLAR SLIDES OVER REAR OF CABINET BEHIND THE 1/4"(6mm) RETURN ON TRIM

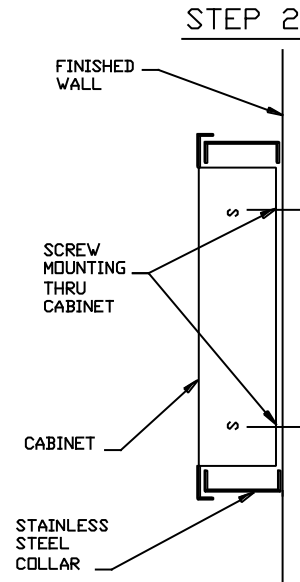

CABINET AND COLLAR ASSEMBLY IS THEN MOUNTED TO WALL

MOUNTING SEQUENCE

SPECIFICATION

Adapter collar for Surface Mounted installations shall be fabricated of type 304, 18-8 alloy stainless steel, N^o22 gauge. All exposed surfaces shall have satin finish. Unit shall be protected for shipment with PVC film easily removed after installation. Unit shall be sized to fit snugly under the 1/4" (6mm) return of the mating cabinet. There shall be no seams on the vertical sides or the corners of the collar. After installation the collar shall be NON-REMOVABLE.

Surface Mounting Collar shall be (Cabinet Model N^o followed by suffix) "- 9" of American Specialties, Inc., 441 Saw Mill River Road, Yonkers, NY 10701-4913.

INSTALLATION

Collar slides over rear of cabinet and under the 1/4" (6mm) return of the mating cabinet. Assembly of collar and cabinet is then placed on mounting location. Standard mounting hardware supplied with cabinet is used as normal.

OPERATION

Surface mounting collars conveniently adapt standard recessed mounting cabinets for use on walls with insufficient depth for recessing or wall materials that would make cutouts impossible. Collar is fabricated to the specific width, height and depth size of the cabinet upon which it is being used.

Accessory Specialties

AMERICAN DISPENSER

Desert Ray Products

WATROUS INC.

THIS MANUFACTURER RESERVES THE RIGHT TO MAKE CHANGES IN DESIGN OR DIMENSIONS WITHOUT FORMAL NOTICE