

To Operate:

- 1. Prime Unit –** After filling dispenser, plug in power to start prime. If unit is plugged in prior to filling dispenser, place hand under spout within sensor location to start prime.

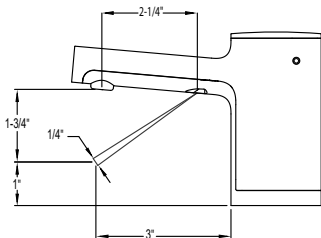

- 2. Standard Dispense –** Place hand under spout within the sensor location for approximately 1/2 second to dispense controlled amount of foam hand soap.



- 3. Adjusting the foam quality –** Foam quality in terms of more or less liquid used to produce the foam can be adjusted by rotating the Portion Control Knob clockwise for more air in the foam and counterclockwise for less air in the foam.



- 4. LED Light Indicators –** When unit is in standby mode and contains soap, LED will have no light. When activated for dispense, solid green LED will light. If red light is flashing, remove hand to allow unit to reset. Hand must be removed for a second activation. LED will flash blue when unit is low on soap.

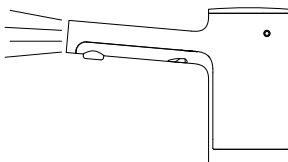

Routine Cleaning and Maintenance:

Using a damp cloth, wipe the chrome-plated exterior of the dispenser daily. Periodically (about 3 to 6 months), it is recommended to flush the system with lukewarm water for cleaning and maintenance.



1. When minimal amount of soap is left in the bottle, fill dispenser with lukewarm water from top to dilute soap.
2. Press on Automatic System Flush Button to flush the system.
3. Once unit is flushed, press Automatic System Flush Button again to stop dispensing.
4. Fill unit with fresh foam soap, and dispense as usual.

Troubleshooting:

1. Soap dispenser does not dispense soap, but you can hear motor running. The green LED lights up when hands are under spout.
 - a. Press the Automatic System Flush Button until soap comes out.
 - b. Press the Automatic System Flush Button again to turn it off.
2. Soap dispenser does not dispense soap and you cannot hear motor running. The green LED does not light up when hands are under spout.
 - a. Be sure power is supplied to unit.
 - b. Be sure Fiber Optic Nut is threaded hand snug only on connector port.

Warranty:

Automatic, Counter-Mounted Top-Fill Foam Soap Dispenser is warranted to be free from defects in workmanship and material under normal usage from the date of purchase for a period of 3 years.

Automatic, Counter-Mounted Top-Fill Bulk Soap Dispenser

INSTRUCTIONS FOR INSTALLATION, OPERATION & MAINTENANCE

BOBRICK MODELS B-900, B-901, B-902, B-905, B-908 FOAM SOAP DISPENSER

Clearances and Mounting Requirements:

- 1-3/8" (35mm) diameter mounting hole required.
- Minimum 18-1/2" (470mm) vertical clearance needed below the counter.
- 5" (127mm) diameter clearance needed below the mounting hole to accommodate bottle and bottom housing.
- Minimum 2-1/4" (57mm) diameter clearance needed for Mounting nut directly below the counter to clear sink rim.
- Recommend drilling mounting hole 6" to 8" (150 to 205mm) from the wall, and 2-1/2" to 3" (64 to 76mm) from sink rim.

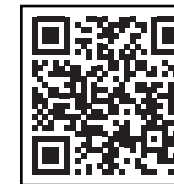

Scan for Automatic Foam Soap Dispenser Installation Video.

For New Installation:

- Refer to mounting template for drilling locations.

For Retrofit:

1. Remove existing dispenser(s).
2. Clean area.
3. Ensure hole is 1-3/8" (35mm) diameter.
4. If necessary, enlarge opening using appropriate hole saw. For granite/marble counters, recommend using a diamond hole saw (consult with stone and granite specialist). If needed, mounting hole should be offset to clear the sink rim. The Mounting nut requires 2-1/4" (57mm) diameter clearance directly below the counter.

Unit Diagram:

Item	Description
1	Top Assembly with Spout, Door and Stem
2	LED Light Pipe
3	Foam Nozzle Tip with Mesh
4	Fiber Optic Insert with Sensor Lenses
5	Rubber Counter Gasket
6	Wave Washer
7	Mounting Nut
8	Stem Locking Nut
9	Foam Mixer Housing
10	Bottom Housing Assembly (includes Soap Bottle)
11	(3) Fiber Optic Cables for Sensor and LED Light Pipe
12	Fiber Optic Connector Tip Assembly
13	Fiber Optic Nut
14	Portion Control Knob
15	Automatic System Flush Button
16	Key Hole
17	BobKey
18	Air Tube
19	Low Soap Level Sensor
20	A/C Adapter Kit with U.S. Plug

For outlets not compatible with U.S. plugs, order Part No. 3974-58.

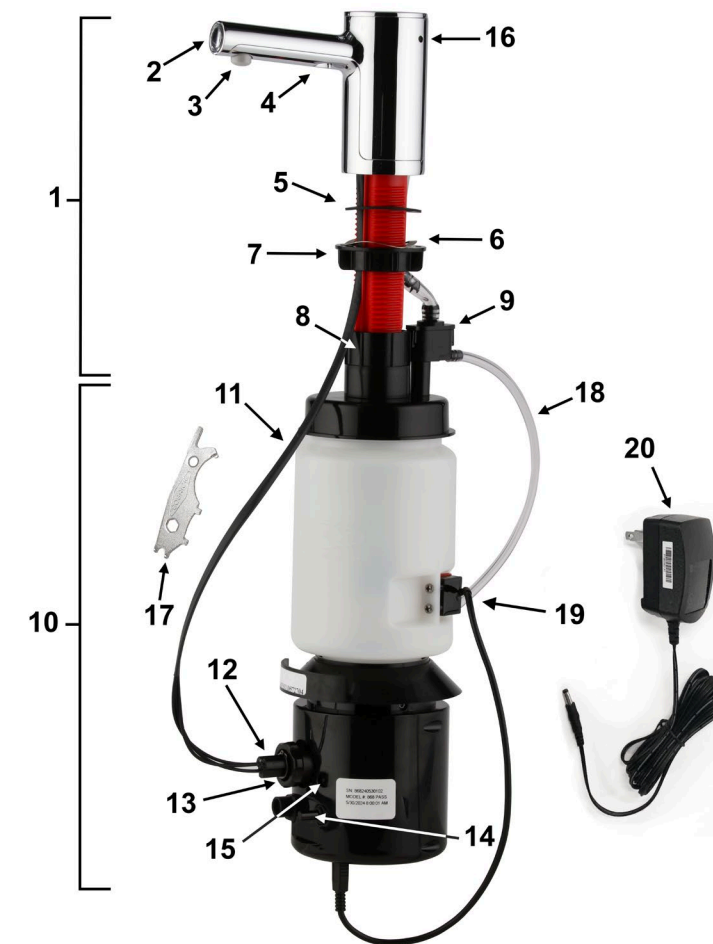

BUILDING VALUE SINCE 1906
BOBRICK.COM

Installation:



1. Place Counter Gasket over mounting hole to align with profile of dispenser.

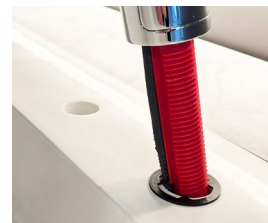

2. Insert Stem with tube and all Fiber Optic Cables carefully through mounting hole.



3. Place the Wave Washer on top of the Mounting Nut Install Mounting Nut on Stem and thread upwards. (Minimum 2-1/4" (55mm) diameter clearance needed below mounting nut).

NOTE: The outer diameter of the Mounting Nut may need to be filed down if space under the counter is tight.

NOTE: Make sure Fiber Optic Cables and Tubing are **INSIDE** Mounting Nut. Do not tighten completely until end of installation.



4. Thread the Stem Locking Nut onto the Stem. The ribs on the Nut are to be towards the top. Once it goes past the two red o-rings, the nut will automatically stop threading.



5. Attach the tubing to the top barb of the Foam Mixer Housing.

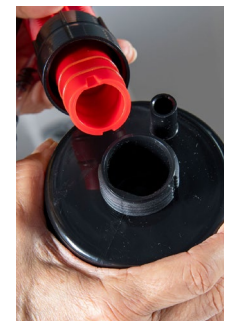

6. The Bottle Cap can only be placed onto the Stem in one orientation.

The flat section on the Stem is to be aligned with the flat section on the Bottle Cap.



7. Rotate the Bottle back and forth to align the flat section of the Stem to the flat section on the Bottle.

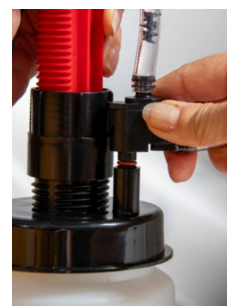

8. Push the Bottle Assembly up onto the Stem while also inserting the Foam Mixer Housing into the hole in the post on the Bottle Cap.

Fully insert the Bottle Assembly over the Stem until it stops. Both red o-rings must be inside the Bottle Cap.



9. While pushing upwards on the Bottle, Thread the Stem Locking Nut down onto the Bottle Cap threads

NOTE: After assembly, hold the Stem and lightly rotate the Bottle back and forth and tug down to be sure it is on tight. If it is loose, repeat Steps 7 and 8.

NOTE: Tug Tubing on Foam Mixer Housing down from under the counter to straighten out the tubing.



10. Connect the small diameter tube from the Foam Mixer Housing to the air tube adapter located on the Bottom Housing.



11. Thread Fiber Optic Connector Tip into Bottom Housing. Keyed feature on Connector Tip ensures Fiber Optic Cables are always located correctly.



12. Thread Fiber Optic Nut onto Connector Port and hand snug only. Do not over-tighten.



NOTE: DO NOT bend or kink Fiber Optic Cables.

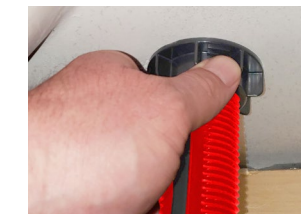

Apply a bead of Silicone around the base of the Top Housing above the counter to prevent spilled soap from going through the mounting hole.

13. Align the Top Assembly above the counter to the desired position and tighten the Mounting Nut against the bottom of counter so the Top Assembly does not easily rotate. Make sure Fiber Optic Cables are not between the underside of the counter and top of Mounting Nut. See Steps 3 and 4.



14. Plug Low Soap Level Sensor USB into the USB receptacle located on the bottom of the Bottom Housing base.



15. Place US plug into AC Adapter and slide down until it clicks into place. For international installations use appropriate adapter from 3974-58.



16. Plug Power Supply into Bottom Housing base.

Replacement Parts List

Part Name	Part No.	Part Name	Part No.
- A/C Adapter	3974-57	- Top Housing Assembly Foam, Brushed Brass	900-25
- International AC Adapter Plug Kit (U. K., Europe, Australia)	3974-58	- Top Housing Assembly Foam, Polished Graphite	901-25
- Mack Gasket Kit	824-167	- Top Housing Assembly Foam, Matte Black	902-25
(To secure Top Assembly under the counter due to irregular counter surface)		- Top Housing Assembly Foam, Brushed Nickel	905-25
- External A/C Multi Adapter Kit	824-201	- Top Housing Assembly, Foam, Polished Chrome	908-25
- Nozzle Tip Replacement Kit Foam	828-310	(Top Housing Assemblies include Installation Hardware Packet and Foam Mixer Housing)	
- Foam Mixer Housing	828-322	- Bottom Housing Assembly, Foam	868-250
- Installation Hardware Packet with Foam Mixer Housing	908-84	- Low Soap Level Sensor Replacement Kit	858-163
(Includes Wave Washer, Counter Gasket, Mounting Nut, BobKey, Stem Locking Nut)		(Includes Sensor, Screws, and Installation Instructions)	

TOP FILL ONLY !

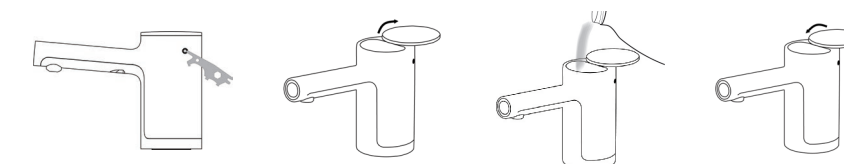

Filling Instructions: (use foam soap only)

Unit will dispense commercially Marketed Bulk Foam Soap.

1. Insert tip of BobKey provided into opening of concealed locking mechanism to disengage door.
2. Door will disengage and rotate clockwise for filling from the top.
3. Fill dispenser with commercially marketed bulk foam hand soap. (Do not fill past midway point in funnel) **(Do not use liquid or lotion soap)**
4. Close door counter-clockwise to lock in place.

MOUNTING TEMPLATE

Automatic, Counter-Mounted Top-Fill Bulk Soap Dispenser

Bobrick Models B-900, B-901, B-902, B-905, B-908 Foam B-990, B-991, B-992, B-995, B-998 Liquid

Required Clearances:

Mounting Hole: 1-3/8" (35mm) diameter

Maximum Counter Thickness: 2" (50mm)

Below Counter:

18-1/2" (470mm) vertical clearance

5" (127mm) diameter directly below mounting hole for bottle and bottom housing.

2-1/4" (57mm) diameter needed for mounting nut directly below mounting hole. If sink rim below the counter is within the clearance area, use a spacer to ensure mounting nut is firmly tightened against, bottom of the counter.

Instructions:

- Using template, locate mounting hole position (on left or right side). Ensure sink and plumbing fixtures **DO NOT** interfere with dispenser above or below the counter (refer to clearances).
- Drill 1-3/8" (35mm) diameter hole.

Sinks with Rim Over the Counter Area:

Unit is not compatible with a sink rim greater than the maximum dimensions listed below:

Option
A

X = 1-1/8" (29mm) Maximum

Y = 1-1/2" (38mm) Maximum

Option
B

X = 2-3/4" (70mm) Maximum

Y = 5/8" (16mm) Maximum

CAUTION:

Rim must not come into contact with activation area.

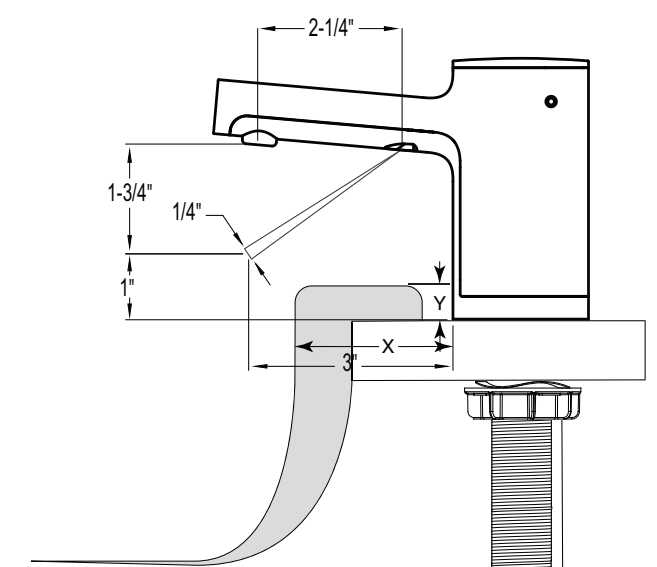
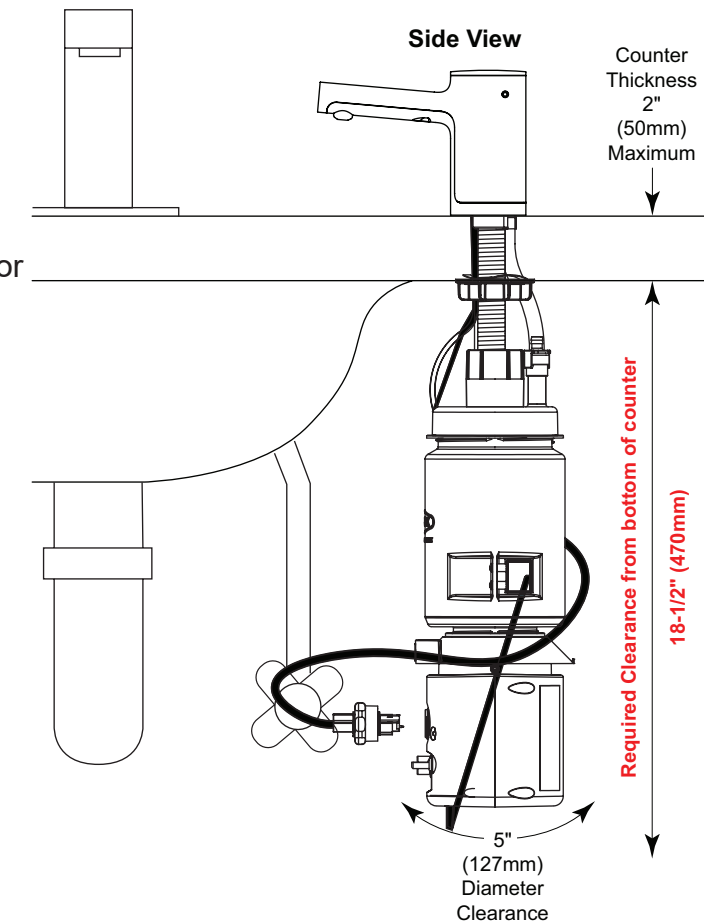

BUILDING VALUE SINCE 1906

© 2024 by Bobrick Washroom Equipment, Inc.
Form No. 998-107 11/4/24

In the U.S.A.: BOBRICK WASHROOM EQUIPMENT, INC.

Los Angeles: 6901 Tujunga Ave., North Hollywood, CA 91605-6213; Tel: (818) 982-9600, FAX: (818) 503-9287
New York: 200 Commerce Drive, Clifton Park, NY 12065-1350; Tel: (518) 877-7444, FAX: (518) 877-5029,
or email: customerservice@bobrick.com

In Canada: BOBRICK WASHROOM EQUIPMENT COMPANY

45 Rolark Drive, Scarborough, Ontario M1R 3B1 • Eastern Canada: Tel: (877) 423-6555 • FAX: (877) 423-8555
• Western Canada: Tel: (877) 423-6444 • FAX: (877) 423-8444 or email: customerservice@bobrick.com

MOUNTING TEMPLATE

LEFT SIDE

View from Top of Counter

Recommended Mounting Distance to Finish Face of Wall

Between 6" to 8" (154 to 203mm)

6" (152mm)

7" (178mm)

8" (203mm)

Drill 1-3/8" (35mm) Diameter Hole

2-1/2" to 3" (64 to 76mm) from Sink Rim to center of Mounting Hole

5-1/2" (140mm)

RIGHT SIDE

View from Top of Counter

Recommended Mounting Distance to Finish Face of Wall

Between 6" to 8" (154 to 203mm)

6" (152mm)

7" (178mm)

8" (203mm)

Drill 1-3/8" (35mm) Diameter Hole

2-1/2" to 3" (64 to 76mm) from Sink Rim to center of Mounting Hole

5-1/2" (140mm)

